

GADDIS G1 CARTRIDGE SEAL RANGE DWG FOR ANSI PUMPS STD BORE

"A" SHAFT SIZE	"B" GLAND O.D.	"C" SEAL O.D.	"D" ST BOX BORE	"E" MIN S.B. DP.	"F" TO FIRST OBST.	"G" ROTARY DEPTH	"H" TO FRONT OF GLAND	"I" SLOT WIDTH	"J" BOLT/STUD DIA	"K" MIN. DIA.	"L" MAX. DIA.	"M" BOLT/STUD DIA.	"N" MIN. DIA	"O" MAX. DIA.
Ø1.125"	Ø4.000"	Ø1.687"	Ø1.750"	.98"	1.39"	.92"	.91"	9/16"	3/8"	2-23/32"	4"	1/2"	2-27/32"	4"
Ø1.375"	Ø4.000"	Ø1.937"	Ø2.000"	.98"	1.38"	.92"	.91"	9/16"	3/8"	2-31/32"	4"	1/2"	3-3/32"	4"
Ø1.750"	Ø5.500"	Ø2.375"	Ø2.500"	1.01"	1.44"	.95"	1.01"	5/8"	3/8"	3-19/32"	5-1/2"	1/2"	3-23/32"	5-1/2"
Ø1.875"	Ø5.500"	Ø2.500"	Ø2.625"	1.01"	1.48"	.95"	1.01"	5/8"	3/8"	3-23/32"	5-1/2"	1/2"	3-27/32"	5-1/2"
Ø2.125"	Ø6.000"	Ø2.750"	Ø2.875"	1.01"	1.45"	.95"	.98"	3/4"	3/8"	3-31/32"	6"	1/2"	4-3/32"	6"
Ø2.500"	Ø6.500"	Ø3.125"	Ø3.250"	1.01"	1.39"	.95"	.92"	3/4"	3/8"	4-11/32"	6-1/2"	1/2"	4-15/32"	6-1/2"
Ø2.625"	Ø6.500"	Ø3.250"	Ø3.625"	1.01"	2.13"	.95"	1.50"	3/4"	1/2"	5-1/8"	6-1/2"	5/8"	5-1/4"	6-1/2"

SLOTTED GLAND PLATE

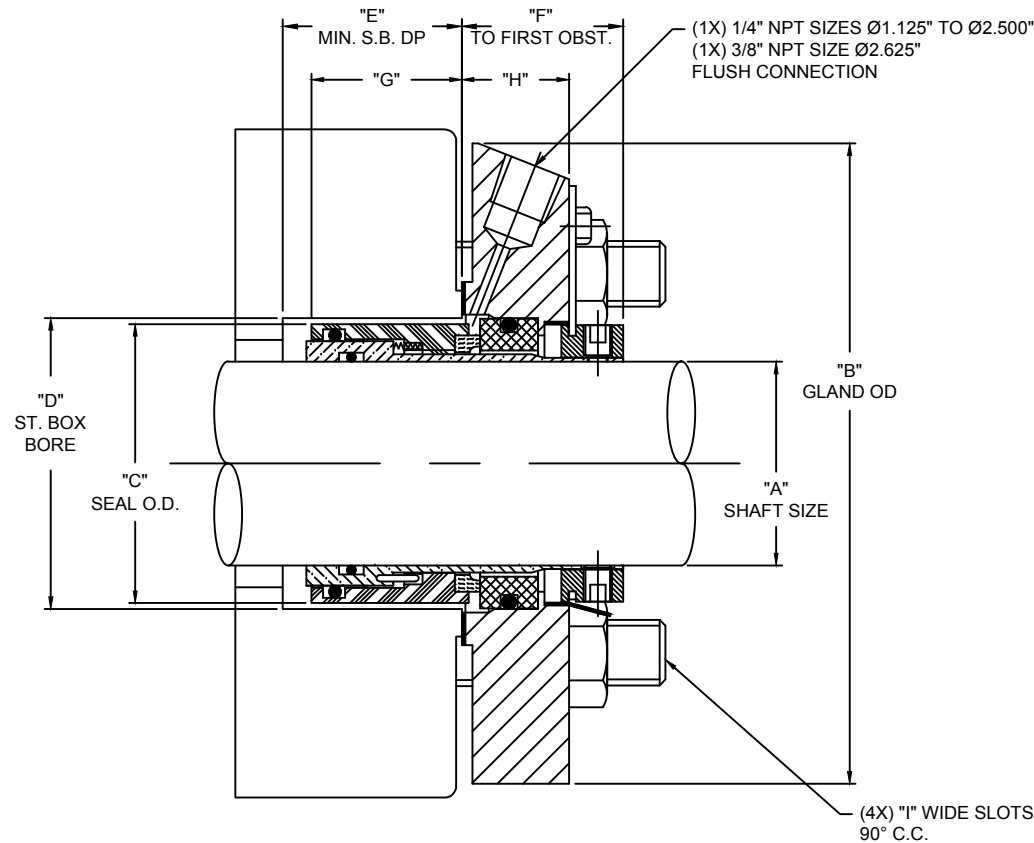

AFLAS® - REGISTERED TRADEMARK - ASahi GLASS COMPANY, LIMITED
 VITON® - REGISTERED TRADEMARK - E. I. DU PONT DE NEMOURS & COMPANY CORPORATION
 TEFLON® - REGISTERED TRADEMARK - E. I. DU PONT DE NEMOURS & COMPANY CORPORATION
 HASTELLOY® - REGISTERED TRADEMARK - HAYNES INTERNATIONAL INC.

BOLT CIRCLE CHART	OPERATING CONDITIONS	MATERIALS OF CONSTRUCTION	TITLE:
FOR "J" DIAMETER BOLTS/STUDS MINIMUM DIAMETER "K" MAXIMUM DIAMETER "L" FOR "M" DIAMETER BOLTS/STUDS MINIMUM DIAMETER "N" MAXIMUM DIAMETER "O"	MAXIMUM SPEED - 3600 R.P.M. MAXIMUM PRESSURE - 250 P.S.I.G. MAXIMUM TEMPERATURE - 350° F WITH AFLAS® & VITON® MAXIMUM TEMPERATURE - 212° F WITH EPR MAXIMUM RUNOUT - 0.003" T.I.R. MAXIMUM END PLAY - 0.006" T.I.R.	ROTARY SEALING FACE - CARBON / SILICON CARBIDE STATIONARY SEALING FACE - SILICON CARBIDE ELASTOMERS - AFLAS® / VITON® / EPR METAL WORK - 316SS SPRINGS - HASTELLOY® "C" GLAND GASKET - TEFLON®	G-1 SINGLE CARTRIDGE SEALS FOR ANSI PUMPS WITH STANDARD STUFFING BOXES SIZE: Ø1.125" TO Ø2.625" SHAFT/SLEEVE DWG #: A118-07-30-01 DATE: 07/30/18